

DC servo motor pump for constant dispenses

RRC Signal Pump

# PUMP MANUAL

MODEL : TP-34RV-15

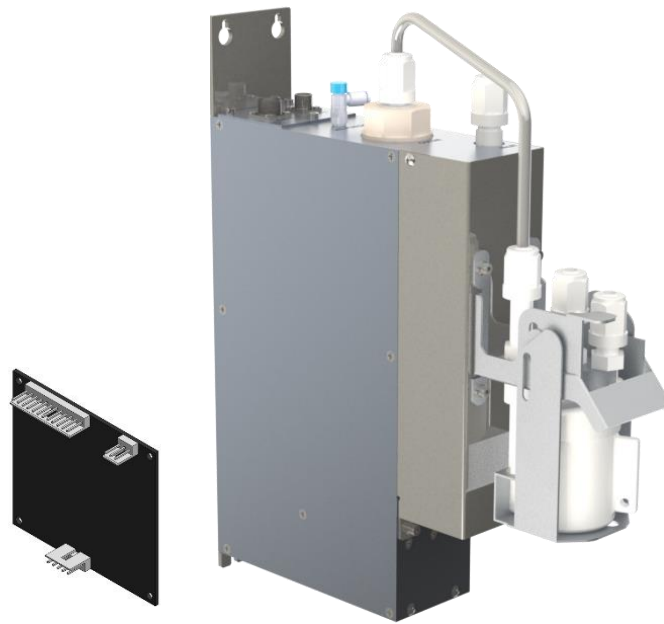

**TALON TECH CO. LTD.**

**CONTENTS**

<b>1. System Configurations</b> .....	<b>1</b>
<b>2. System Specifications</b> .....	<b>2</b>
2-1. Pump [TP-34RV-15].....	<b>2</b>
<b>3. System In/Exterior Names</b> .....	<b>3</b>
3-1. Pump In/Exterior Names.....	<b>3</b>
3-1-1. Pump Name Explanation.....	<b>4</b>
3-2. I/F Board Exterior Names.....	<b>4</b>
3-2-1. I/F Board Name Explanation.....	<b>4</b>
<b>4. Wiring &amp; Signal Interface</b> .....	<b>5</b>
4-1. ACT/MARK Type CON1 Pin Assign [Motor Cable].....	<b>5</b>
4-2. ACT/MARK Type CON2 Pin Assign [Track Cable].....	<b>5</b>
<b>5. Maintenance</b> .....	<b>6</b>
5-1. Pump Parts Dis/Assembly.....	<b>6</b>
5-1-1. Pump Cover Dis/Assembly.....	<b>6</b>
5-1-2. Driving Shaft Condition Check & Grease up on Ball Screw.....	<b>6</b>
<b>6. Recommended Spares/Mechanical Dimensions</b> .....	<b>7</b>
6-1. TP-34RV-15 Spare Parts.....	<b>7</b>
6-2. Pump Dimensions.....	<b>8</b>
6-2-1. Side View.....	<b>8</b>
6-2-2. Front/Rear View.....	<b>8</b>
6-3. Installation Method.....	<b>9</b>
6-3-1. Pump Installation Sequence.....	<b>9</b>
6-3-2. Piping Method.....	<b>9</b>
6-3-3. Cable Connection Method [ACT Type].....	<b>10</b>
6-3-4. Cable Connection Method [Mark Type].....	<b>11</b>

# 1 System Configurations

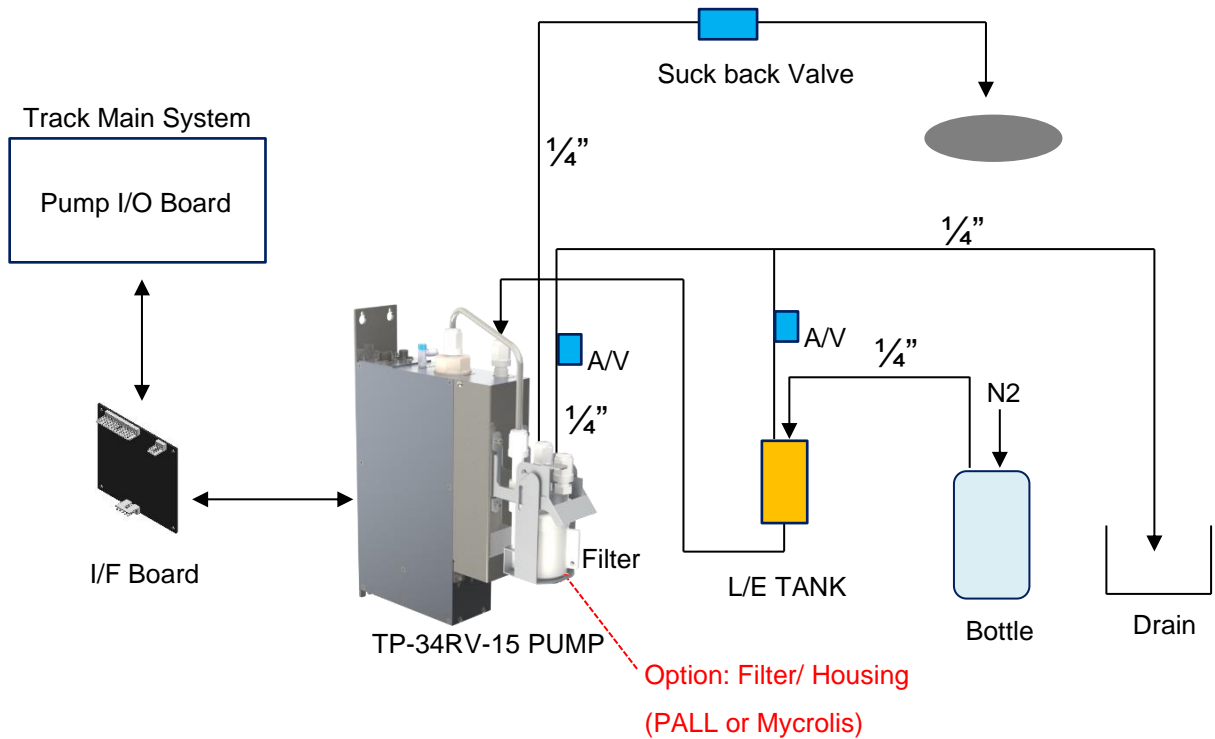

TP-34RV-15 pump can be used as the above configuration and has been developed conveniently to be compatible with Mark & ACT series systems.

Be careful to use the pump by following this manual or Talon Tech's acceptance. Or, other defects should be paid even under the warranty period.

## ※ Features & Merits

1. All the PR contacting points are made by Teflon.
2. Driving Method : Outer type Edgeless Bellows, No ripple, & No shaking.
3. Signal is same as RRC Pump. (ACT/MARK)
4. Talon I/F board replaces RRC driver.

## 2 System Specifications

### 2-1 Pump [TP-34RV]

ITEM	SPEC	REMARKS
Dispense Volume Range	0.5 ~ 15.0ml	
Dispense Pressure	0.2Mpa (2kgf/cm <sup>2</sup> )	
Dispense Volume Resolution	±0.03ml	
Dispense / Reload Rate	0.1ml/sec ~ 2.0ml/sec	
Dispense Repeatability	≤±0.05 (2.2cp, 23°C)	
Viscosity	Max : 800cp	
Driver System	DC Servo Motor Driver Current : 300~500mA/Cycle	
Control System Power	Motor Power : DC24V, Home Sensor : DC5V~24V	
Input Pulse VS Dispense Volume	699 pulse / 1ml(IPA), 889 pulse / 1ml(440cP)	
Input Pulse VS Encoder Output Pulse	Full Step-1:1	
Resist In/Out	¼ Inch Teflon	
Ambient Temperature	16 ~ 30°C	
Weight	4.0kg	
Pump Dimension	W : 60mm, L : 284.7mm, H : 327mm	

### 3 System In/Exterior Names

#### 3-1 Pump In/Exterior Names

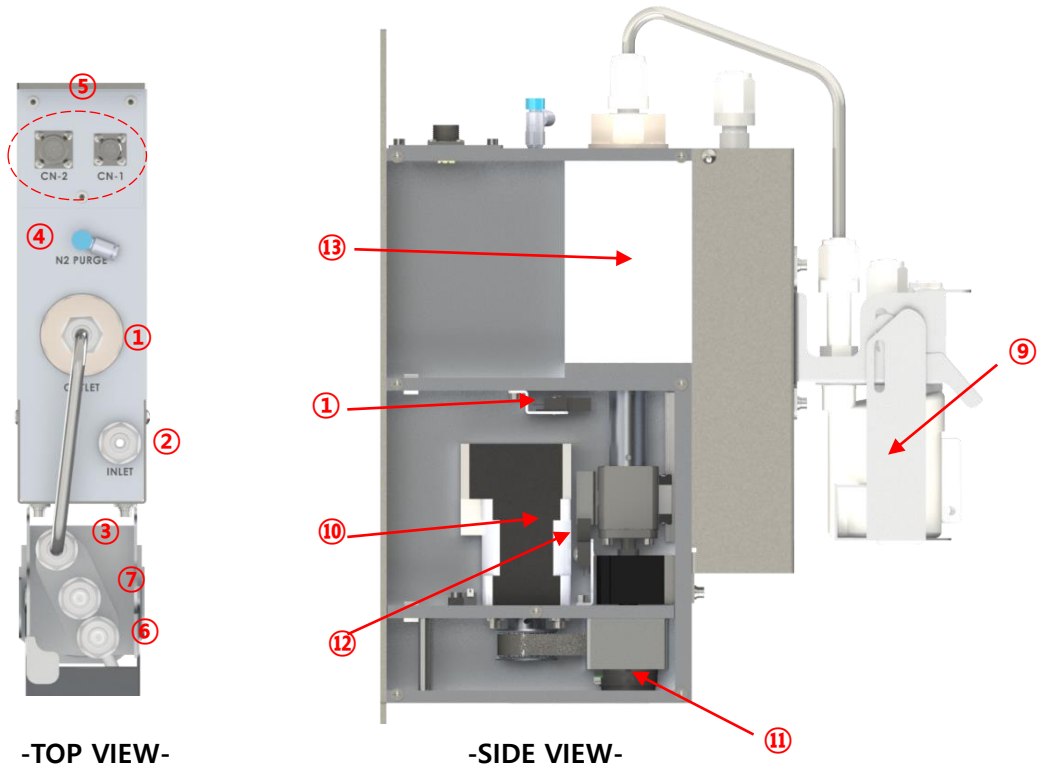

-TOP VIEW-

-SIDE VIEW-

#### 3-1-1 Pump Name Explanation

- ① **Pump Outlet**  
- Chemical Dispense port (¼ Inch Teflon)
- ② **Pump Inlet**  
- Chemical Supply port (¼ Inch Teflon)
- ③ **Filter inlet**  
- Chemical supplied from Pump outlet to filter inlet (¼ Inch Teflon)
- ④ **N2 Purge Port**  
- Air Cooling function (4Ø Air Tube)
- ⑤ **Pump Connector CN1, CN2**  
- CN1(Motor) : Connector for Pump Operation (Round Panel Mount 5P Female)  
- CN2(Track) : Connector for Pump Operation (Round Panel Mount 8P Female)
- ⑥ **Filter Vent**  
- Bubble inside the filter vents (¼ Inch Teflon)
- ⑦ **Filter Outlet**  
- Chemical inside the filter goes out (¼ Inch Teflon)

- ⑧ **Pump Cylinder**
  - Room for PR temporarily stays
- ⑨ **Filter Bracket (option: sales separately)**
  - Housing for filter
- ⑩ **DC Servo motor**
  - Main item to work out pump.
- ⑪ **Encoder**
  - Check out the motor's revolution and judge the moving condition
- ⑫ **Home Sensor**
  - Sensor for the pump's come back to the original position
- ⑬ **Limit Sensor**
  - Safety sensor that works when the motor goes over the limit.

### 3-2 I/F Board Exterior Names

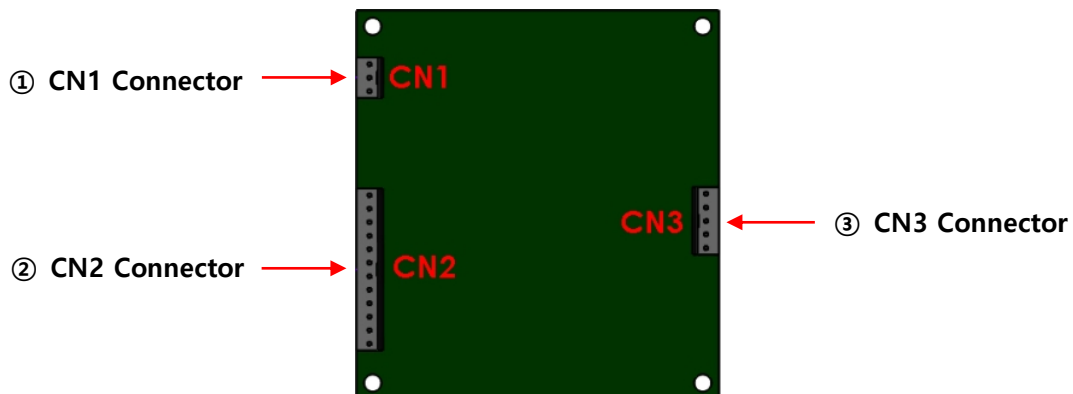

#### 3-2-1 I/F Board Name Explanation

- ① **CN1 Connector**
  - 3P Connector linked to Pump I/O Conn Board CN130
- ② **CN2 Connector**
  - 12P Connector linked to Pump I/O Conn Board CN1~9
- ③ **CN3 Connector**
  - 5P Connector linked to the existing RRC Pump (TP-34RV Pump) CN1

## 4 Wiring & Signal Interface

### 4-1 ACT/MARK Type CN1 Pin Assign [Motor Cable]

ACT Type Pin Assign			
Pin NO.	Signal Name	Color	Description
A	CW+/CCW+	White/Gray	DC Servo Motor
B	CW-	Black	
C	CCW-	Brown	
D	+24V/ACT	Orange	
E	G24V/ACT	Black	

### 4-2 ACT/MARK Type CN2 Pin Assign [Track Cable]

ACT Type Pin Assign			
Pin NO.	Signal Name	Color	Description
A	EA+	Blue	Encoder A Phase Output
B	EA-	Orange	
C	EB+	Yellow	Encoder B Phase Output
D	EB-	Gray	
E	G5/LGC	Black	GND
F	Home Sensor	Blue	Output (Open Collector), 5VDC, 1c=100mA
G	+5V/LGC	Red	5V $\pm$ 0.25V / 0.2A
H	TH S/W	Green	GND

## 5 Maintenance

### 5-1 Pump Parts Dis/Assembly

#### 5-1-1 Pump Cover Dis/Assembly

1. Open the cover by loosening the pump cover mounting screw (8ea) with screw driver (+) as the below [PIC 1].

**[Notice]**

**Be careful not to cut the fingers on cover open.**

**Don't disassemble the drive shaft parts inside the pump.**

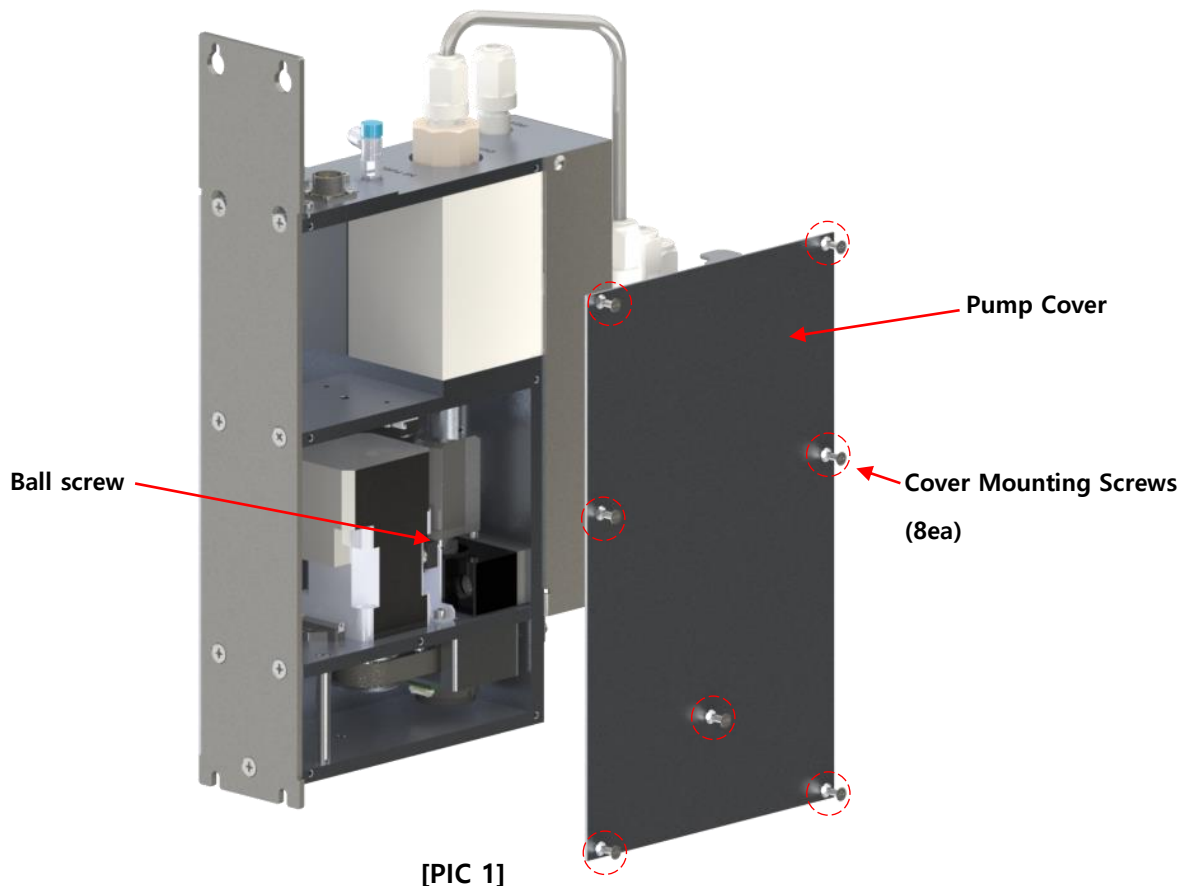

[PIC 1]

#### 5-1-2 Driving Shaft Condition Check & Grease up on Ball Screw

1. Check the motor's vibration & noise when the pump works.
2. Check the bolts tightening condition and ball screw worn-out condition.
3. Check any interruption between cables & moving parts.
4. Check the conditions of linear bushing /shaft when the pump works.
5. Grease up on ball screw & LM linear bushing.
6. Grease up every 6 months.



**6**
**Recommended Spares / Mechanical Dimensions**
**6-1 TP-34RV-15 Spare Parts**

Division	Part NO.	Description	Qty
Pump	TL-34RV-15-TA-001-2	Cylinder	1
	TL-34RV-15-TA-006-6	Edgeless Bellows (15cc)	1
	TL-34RV-15-TA-003	Pump in/ outlet Fitting	2
	TL-34RV-15-TA-007-1	Pump in/outlet Nut	2
	TL-34RV-TA-005	Bulkhead Union (Flowell)	1
	TL-34RV-TA-006	¼ Inch PFA Fitting Nut (Flowell)	3
	TL-34RV-EB-001	Motor	1
	TL-34RV-MA-001-1	Ball Screw(15cc)	1
	TL-34RV-MA-002	Support Unit	1
	TL-34RV-MA-003-1	LM Guide(70mm)	1
	TL-34RV-ET-001	Motor Pulley	1
	TL-34RV-ET-002	Ball Screw Pulley	1
	TL-34RV-ET-003	Timing Belt	1
	TL-34RV-ET-004	O-Ring (Cylinder)	1
	TL-34RV-ET-005	O-Ring (Cylinder)	1
	TL-34RV-ET-006	O-Ring (End Cap)	2
	TL-34RV-ET-007	O-Ring (In/out fitting)	2
	TL-34RV-ET-008	O-Ring (In/out fitting)	2
	TL-34RV-EB-002	Encoder	1
	TL-34RV-EA-001	Photo Sensor	2
TL-34RV-CA-001	Air Speed Control	1	
I/F Board	TL-34RV-EB-003	I/F Board	1

**6-2 Pump Dimensions**

**6-2-1 Front / Side View**

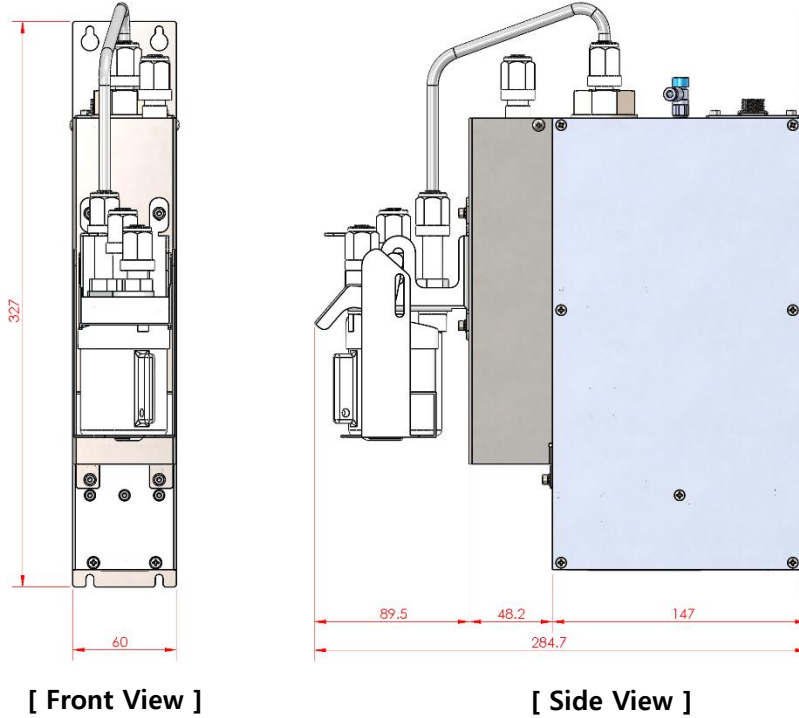

**6-2-2 Top / Rear View**

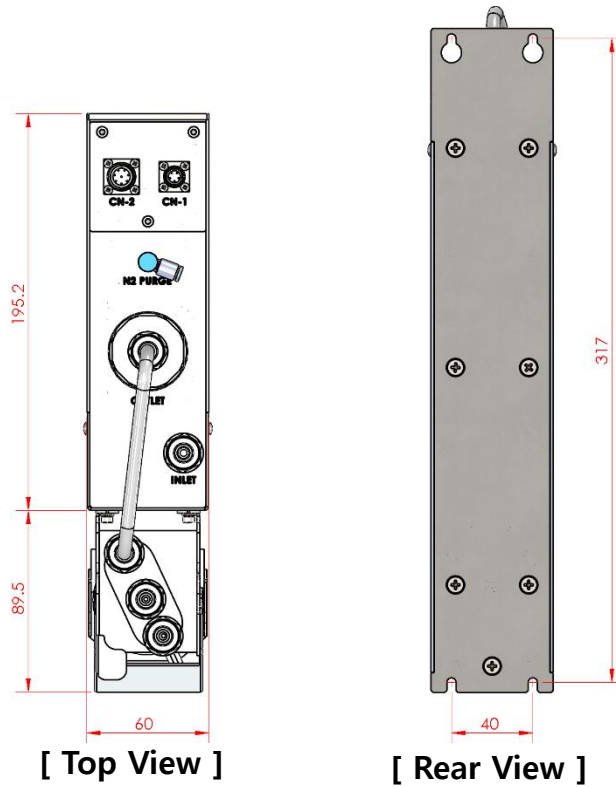

**6-3 Installation Method**

### 6-3-1 Pump Installation Sequence

1. Keep the space for the pump installation.
2. Make the bolt tap for M4 on the installation position.  
(check the size)
3. Tighten the panel mount plate with 4 pieces of M4 screws.

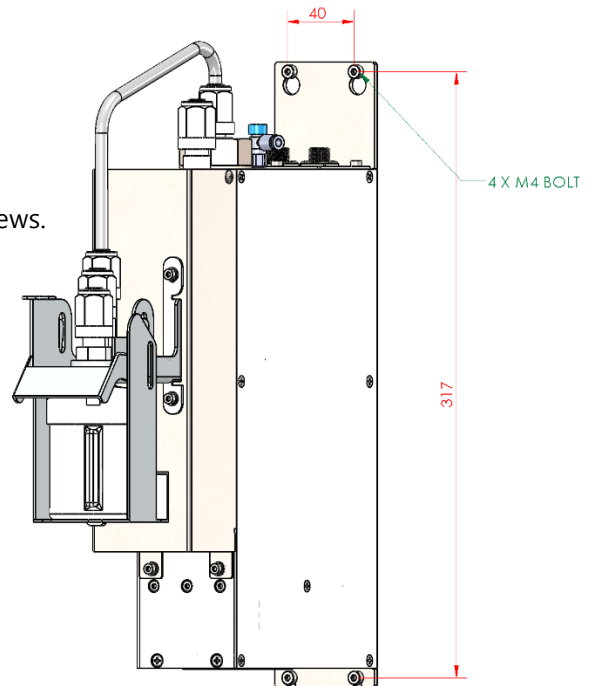

### 6-3-2 Piping Method

#### 1. PR Tube Piping

- 1) Insert ¼" union nuts on tube and tighten nuts.  
(Pump Inlet/Filter outlet/Filter Vent)

#### 2. Purge Line Piping

- 1) Connect 4Ø of air tube into the air speed control valve.

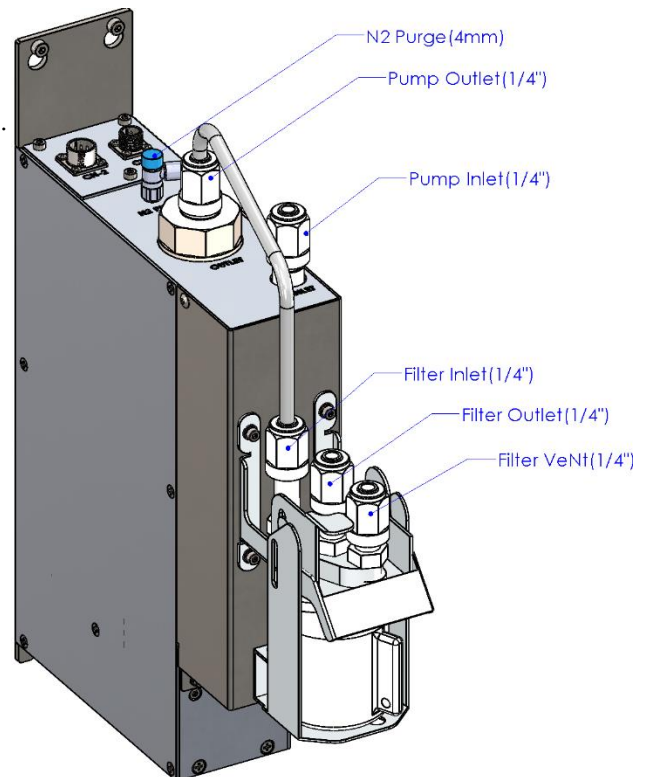

**6-3-3 Cable Connection Method [ACT Type]**

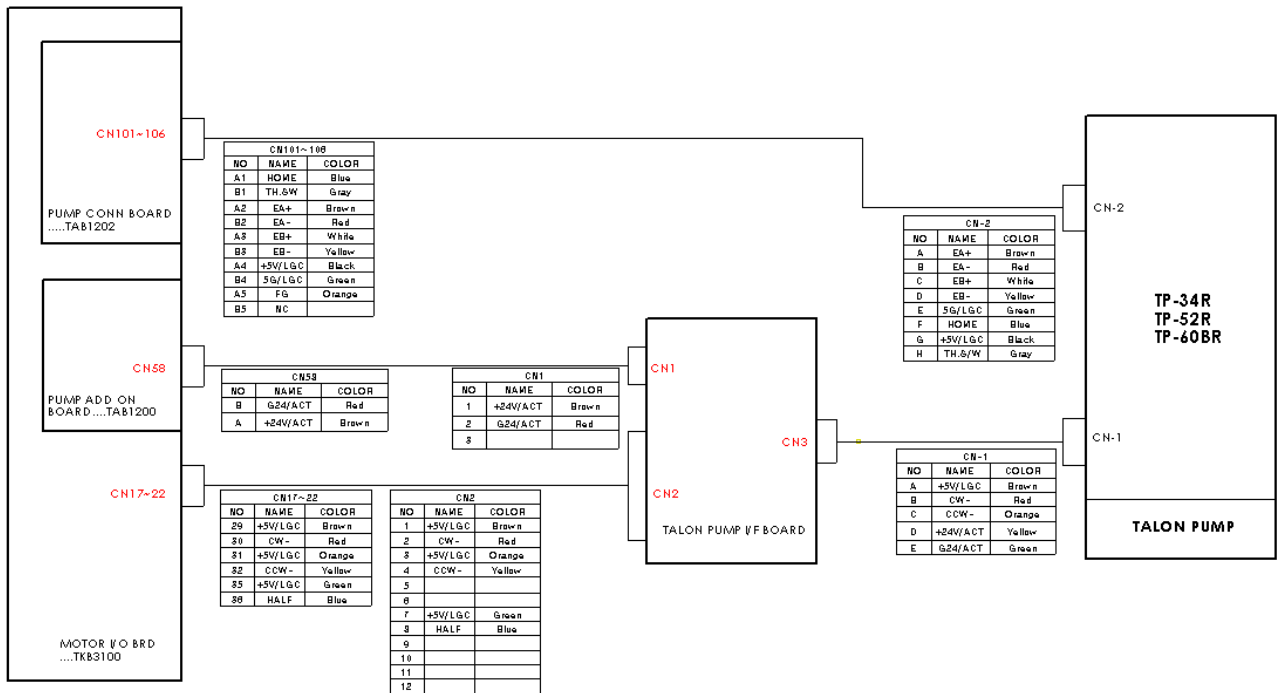

RRC Motor Driver (CSD5807)



Talon Pump IF Board (REV6.1)

1. De-install RRC pump and install TP-34RV-15 Pump.  
(CN1 & CN2 Connectors are connected to TP-34RV pump same as RRC pump.)
2. De-install RRC Driver (CSD5807) and install Talon pump I/F Board (only for TP-34RV-15).
3. RRC Driver's Connector CN1, CN2, & CN3 are connected to the same position of Talon I/F board.

**[Notice]**

**TP-34RV Pump uses DC Servo Motor. So, Motor Driver is built-in inside the motor.**

**6-3-4 Cable Connection Method [Mark Type]**

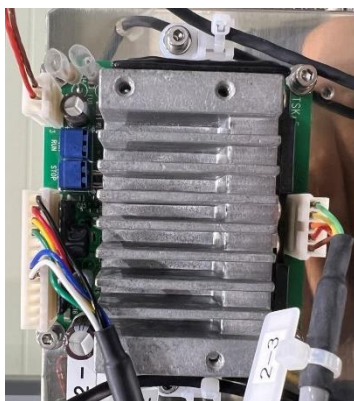
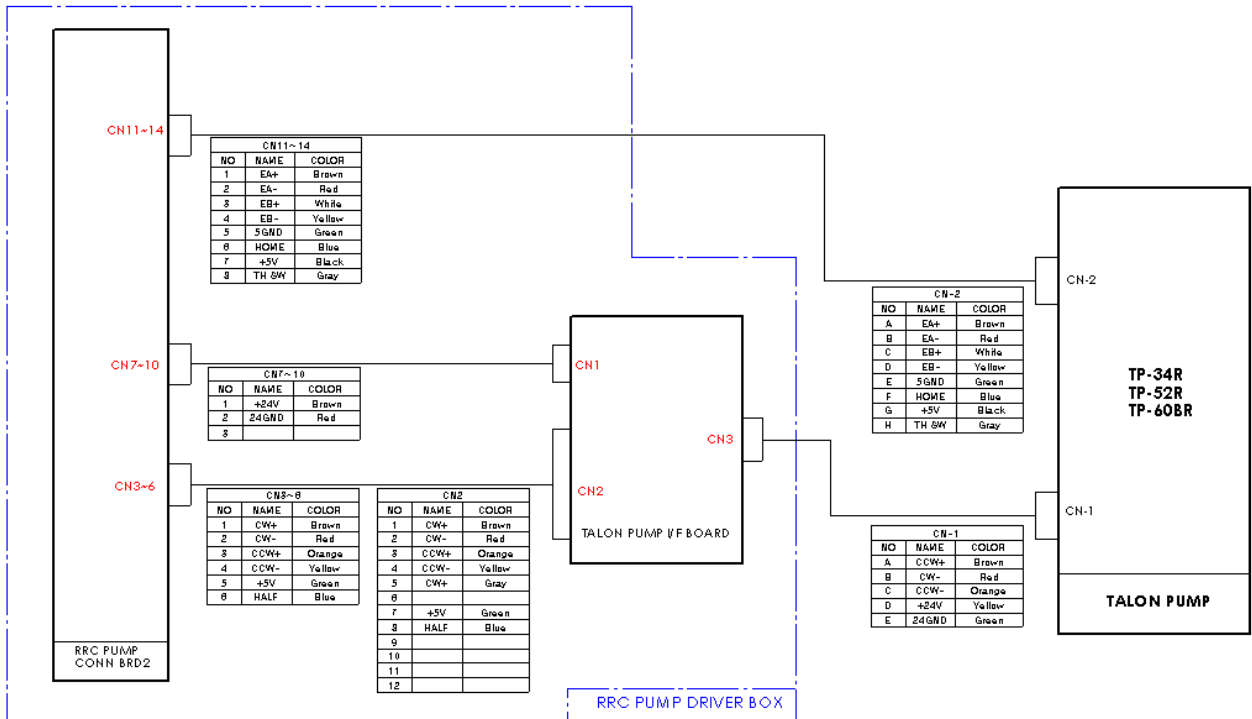

RRC Motor Driver (CSD5807)

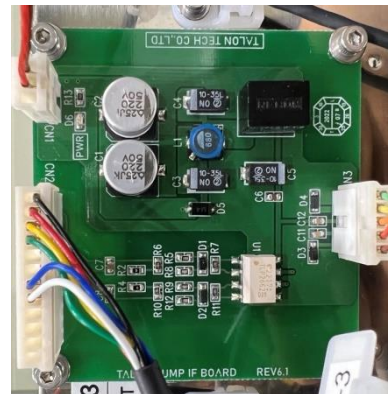

Talon Pump I/F Board (REV6.1)

1. De-install RRC pump and install TP-34RV-15 Pump.  
(CN1 & CN2 Connectors are connected to TP-34RV pump same as RRC pump.)
2. De-install RRC Driver (CSD5807) and install Talon pump I/F Board (only for TP-34RV-15).
3. RRC Driver's Connector CN1, CN2, & CN3 are connected to the same position of Talon I/F board.

**[Notice]**

**TP-34RV Pump uses DC Servo Motor. So, Motor Driver is built-in inside the motor.**

<THE END>